



# STAINLESS STEEL CYLINDER

## OPTIONS

The following options are available with Clippard stainless steel cylinders. Available options are shown by the abbreviations noted in the information shown with each standard cylinder.

### Fluorocarbon Seals -V

This option is used in applications where chemical resistance, compatibility and temperature become an issue. Temperature ranges: -20 up to 400°F.

### Cushions -C

(Front Cushion Only) -F

(Rear Cushion Only) -R

Clippard's cushion cylinders offer an adjustable cushion to slow the cylinder near the end of the stroke to reduce impact and prolong cylinder life. Our adjustment needle is held captive to prevent the needle from blowing out. The cushion can be adjusted to have a dead stop 1/2" from end of stroke or adjusted to have virtually no effect on the action of the cylinder. See specific cylinder specifications for availability of this option.

### No Rod Threads -N

Rods are provided with no threads when this option is ordered.

### Magnetic Piston -M

Clippard stainless steel pneumatic cylinders that are equipped with an internal magnet can be used with the Reed Switch and GMR Sensor. By accurately sensing the magnetic field of the piston when it passes beneath the sensor, the position of the rod piston is determined, and the feedback signal is created. Use of this option may add to the overall length of the cylinder. See specific cylinder listings on the following pages for availability and details of the overall length adder.

### Rod Wipers -W

Rod Wipers are added to cylinders in applications where a liquid wash could dry out the rod seals of a double acting cylinder.

### Heavy Spring -H

In single acting, reverse acting or spring bias cylinders the standard spring force can be changed by ordering the -H option. The spring forces for the heavy springs are shown on page 3.

### Private Label Option

Call Clippard for further information about private label options.

If you can't find a cylinder to suit your needs call your Clippard distributor to inquire about custom cylinders.

### Bumpers -B

Internal polyurethane bumpers are supplied for applications where the cylinder is cycled with a light load and/or high speeds. The elastic bumpers reduce noise and shock to the load. Use of this option may add to the overall length of the cylinder. See specific cylinder listings on the following pages for availability and details of the overall length added. Maximum temperature 200°F.

### Side Ported -S

Side ported rear heads are sometimes needed when the standard cylinder has the rear port out the back. This option changes the design of the rear head so the rear port is located on the side of the cylinder. Overall length of cylinder changes with this option.

### Rod Extensions

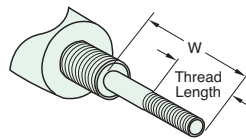

If a special rod extension is required, please refer to the drawing at left. For a special rod extension on single- or double-acting cylinders, indicate desired "W" when rod is at rest

(retracted) with no pressure to either port. For reverse acting cylinders, indicate "W" when rod is at rest (extended) with no pressure to either port.

W = \_\_\_\_\_ Thread Length = \_\_\_\_\_

### Rotated Ports

Option #	Rear Port	Front Port
P2	B2	A2
P3	B1	A2
P4	B4	A2
P5	B3	A2
P6	B4	A1
P7	B3	A1
P8	B2	A1

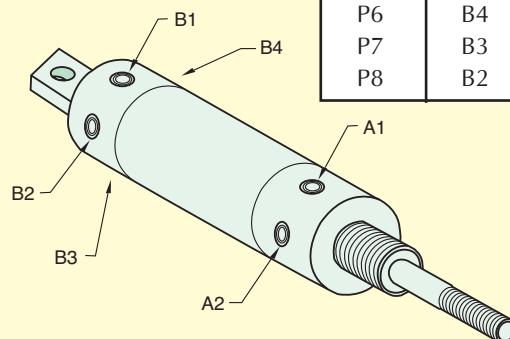

This option is used in applications where ports need to be rotated to accommodate a specific space requirement or port orientation for the fittings and tube attachments. The diagram explains the options and orientation of the ports. See the specific cylinder to find availability of these options.